



# VLF-Y208 Yoke

## VLF208 Mounting Bracket

### Yoke-type mounting bracket for Community's VLF208 compact subwoofer

The **VLF-Y208** yoke bracket is designed to mount the VLF208 subwoofer in either a vertical or horizontal orientation. It is engineered to provide a high margin of safety when supporting the VLF208 subwoofer. Yokes are manufactured of steel, covered with a durable powder-coat finish, and are available in either black or white to match the color of the enclosure.

The VLF-Y208 yoke bracket is provided with the hardware required to attach it to the loudspeaker enclosure. No additional hardware is provided to attach the yoke bracket to the mounting surface. Such hardware must be supplied by the installer and should be sized and rated for the weight load of the loudspeaker, keeping in mind that additional torque load may occur when focusing the loudspeaker within the yoke assembly. The installer is solely responsible for determining if the mounting surface is capable of safely supporting the weight load of the loudspeaker, and for selecting appropriate hardware to install it.

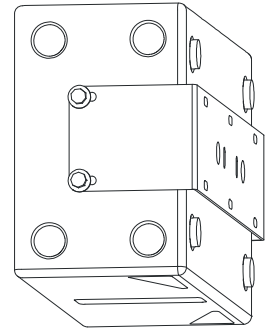

### VLF-Y208 Parts List

- Mounting Yoke (1)
- M10 40 mm Bolt (4)
- M10 Flat Washer (4)
- M10 Split Lock Washer (4)

*The installer must supply all other hardware for the installation.*

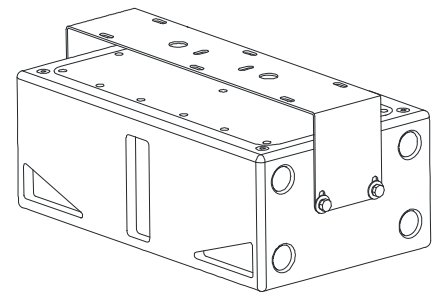

### Yoke Dimensions

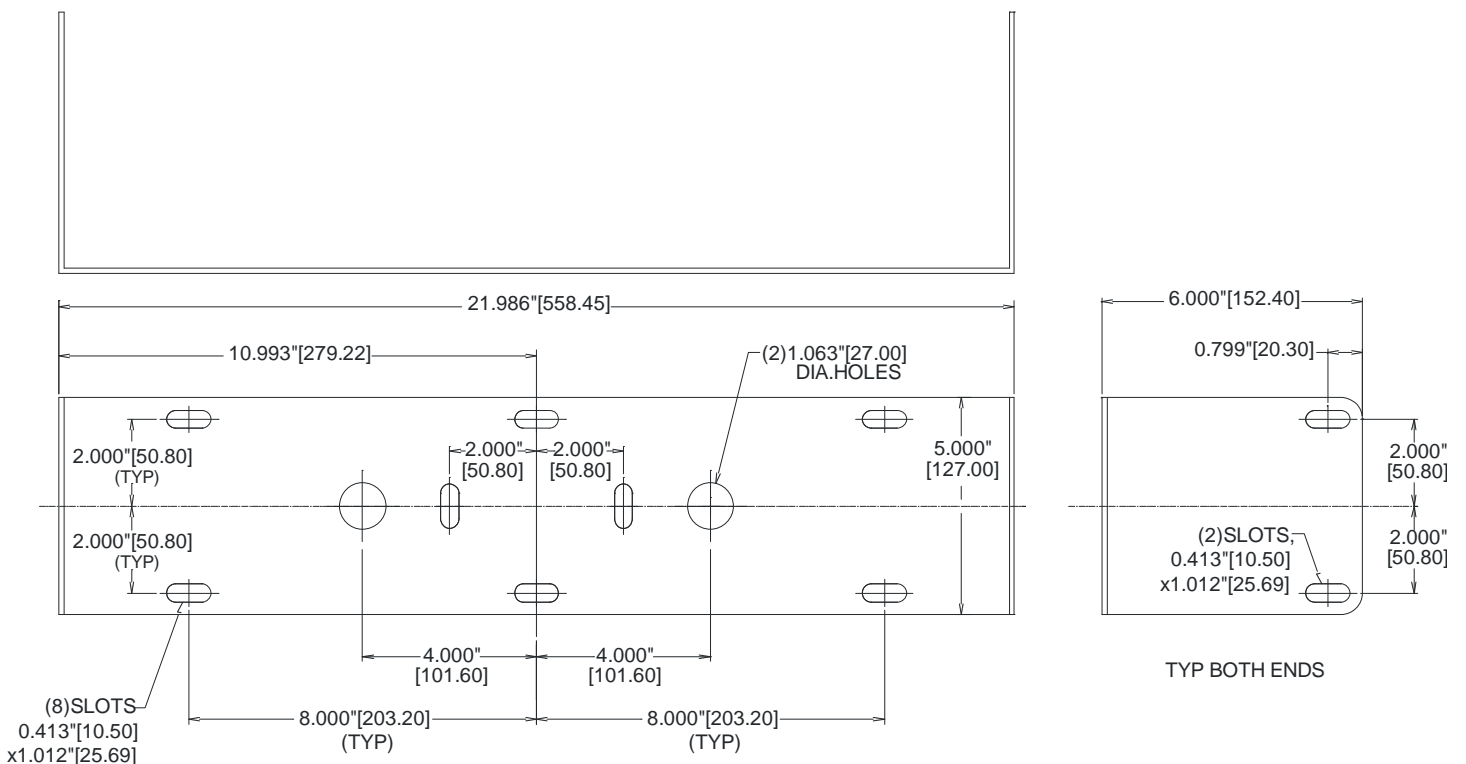

**Danger:** All rigging points on each enclosure must be fitted with either optional mounting hardware or they must remain sealed with the flat-head Allen screws that come installed in the enclosure. The flat-head Allen screws pass through the birch plywood panels and fasten to internal steel rigging brackets, thereby providing structural integrity. Without these Allen screws, the structural integrity of the plywood enclosure would rely solely on the adhesion of the glue joints, which over time could deteriorate. Therefore, **all rigging fittings must have fasteners in place** so that the enclosure may be safely 'flown' or suspended overhead. Additionally, if the rigging fittings are not sealed, air leaks will occur in the enclosure that will compromise the low frequency performance with distortion and reduced output.



**Warning:** VLF rigging fittings are rated at a Working Load Limit of 150 lbs (68 kg) with a 15:1 safety margin. No single rigging fitting should ever be subjected to a load that is greater than 150 lbs. When multiple enclosures are suspended one above the other, it is the installer's responsibility to insure that the combined weight load does not exceed the Working Load Limit on any one rigging fitting. This is particularly important if the enclosures are angled steeply downward (or upward), as most or all of the weight may be supported by the rear (or front) points only. Failure to heed this warning could result in injury or death!

### VLF-Y208 Assembly

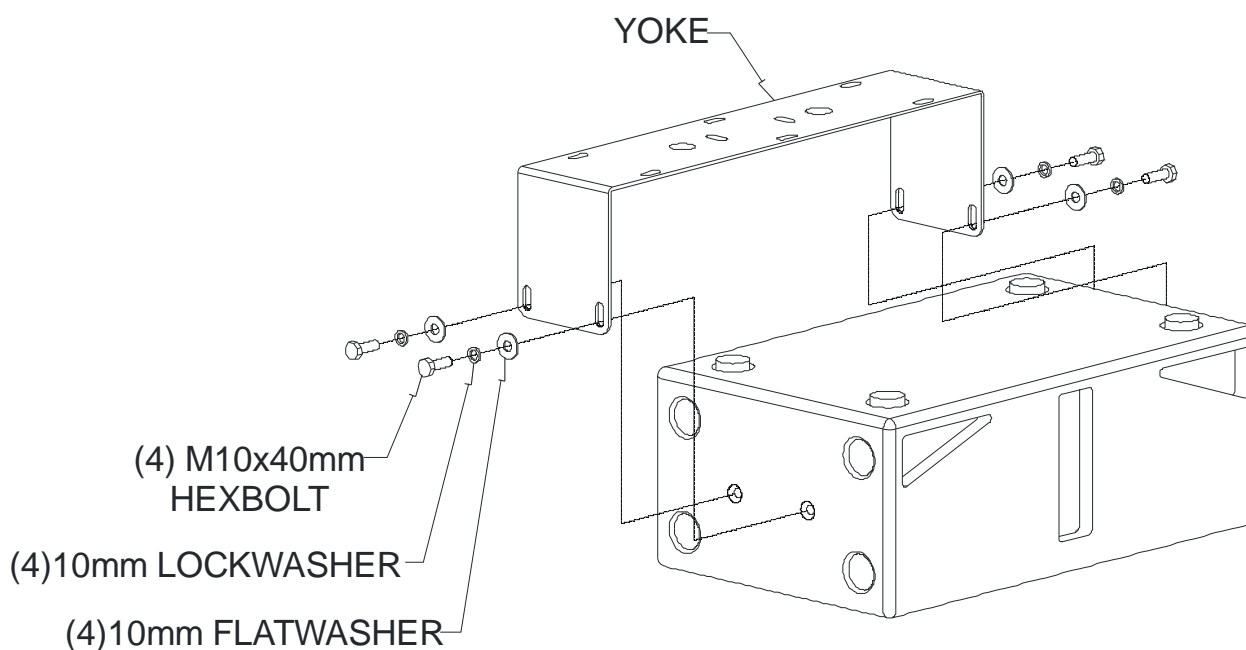

### VLF-Y208 Assembly Instructions

1. Before installing the loudspeaker in the yoke, the yoke should first be attached to the mounting surface. No hardware is provided for this purpose. Such hardware must be supplied by the installer, and should be rated for the weight load of the enclosures. The installer is solely responsible for determining if the hardware used to mount the yoke is adequately sized and rated, and if the structure it is attached to is capable of safely supporting the weight load of the enclosure.
2. Installing the loudspeaker in the yoke is straightforward. First remove two of the flat-head Allen screws that come installed in the loudspeaker, two on each side panel.
3. Fit each of the four M10 x 40mm bolts with a lock washer and a flat washer, then pass each bolt through the yoke bracket into the loudspeaker's rigging fitting. Tighten the fasteners until snug. The bolts should be tightened to a torque of approximately 12 to 15 foot-pounds, using a torque wrench. Do not overtighten!



**Caution:** Installation of loudspeakers should only be performed by trained and qualified personnel. It is strongly recommended that a licensed and certified professional structural engineer approve the mounting design.



Community Professional Loudspeakers, 333 East Fifth Street, Chester, PA 19013 USA  
Phone (610) 876-3400 | Fax (610) 874-0190 | [www.communitypro.com](http://www.communitypro.com)