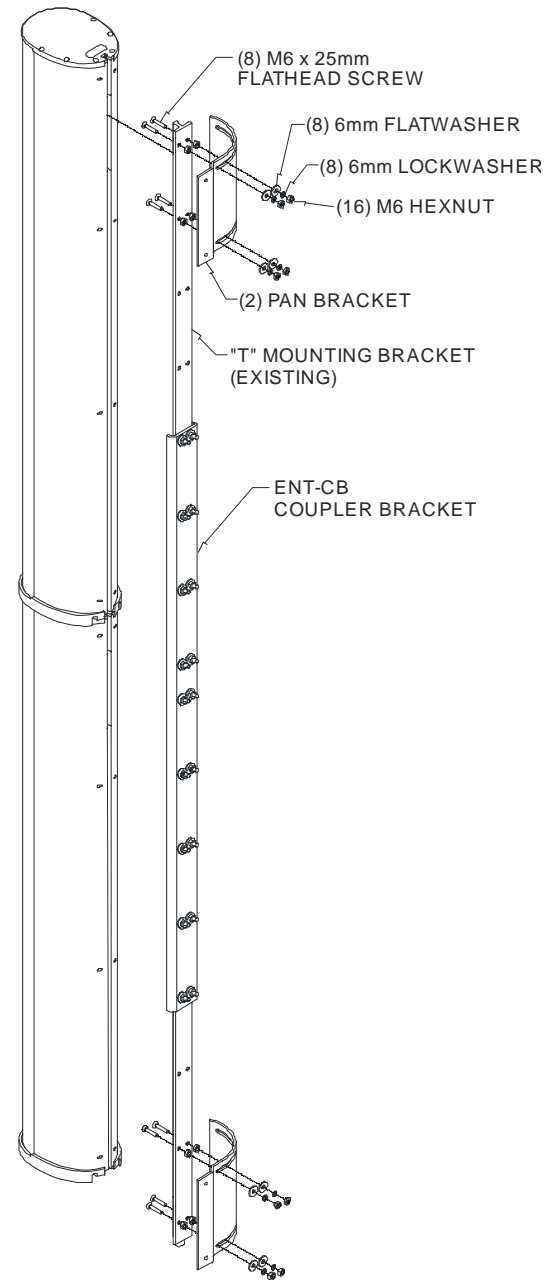



Figure 4: Pan Bracket Kit Assembly Diagram (Two Columns)



 **Outdoor Installation Tip:** Whenever ENTASYS column loudspeakers are installed outdoors, or exposed to direct rain, water or precipitation, the loudspeaker enclosure must be angled downward at a minimum of two (2) degrees.



WARNING: The bolts used and wall material into which the Pan Bracket assembly is bolted must be capable of supporting the load of the ENTASYS array to be mounted. It is the responsibility of the installer to verify these items.



CAUTION: Installation of loudspeakers should only be performed by trained and qualified personnel. It is strongly recommended that a licensed and certified professional structural engineer approve the mounting design.



Community Professional Loudspeakers
333 East Fifth Street, Chester, PA 19013-4511 USA
Phone (610) 876-3400 | Fax (610) 874-0190
www.communitypro.com



ENT-PB

ENTASYS Pan Bracket Kit

Left-to-Right/Right-to-Left Pan Bracket Kit for Community's ENTASYS Column Line Array System

The ENTASYS Pan Bracket Kit, designated ENT-PB, can be used to mount up to five ENTASYS columns flush on a wall while providing a means to rotate the entire array up to 80° (5° - 85° aiming angles) about a vertical axis. The Pan Brackets may be installed on a wall in either a left-hand or right-hand orientation as required for the desired aiming of the array. The Pan Bracket Kit consists of two curved metal brackets and all of the hardware required to attach these brackets to the T-Bar Mounting Bracket included with the ENTASYS Column Line Array System.



WARNING: A pair of ENTASYS Pan Brackets must not be used to support more than five (5) ENTASYS loudspeakers. Attempting to do so will exceed the Working Load Limit of the bracket and could result in the failure of the bracket and potentially result in severe injury and/or loss of life.

All parts in the kit are engineered to provide a high margin of safety when used in accordance with these instructions. The brackets are manufactured of steel and are covered with a durable powder-coat finish. Kits are available in either black or white to match the color of the enclosure.

Table 1: Pan Bracket Kit Part Numbers

Part No.	Description
ENT-PB	ENTASYS Pan Bracket Kit, Black
ENT-PBW	ENTASYS Pan Bracket Kit, White

No hardware is provided to attach the ENTASYS column assembly and Pan Brackets to the mounting surface. Such hardware must be supplied by the installer and should be sized and rated for the weight load of the enclosures. The installer is solely responsible for determining if all rigging components that are used to mount or suspend the enclosure(s) are adequately sized and rated, and if the structure they are mounted or suspended from is capable of safely supporting the aggregate weight load. If multiple enclosures are suspended one above the other, it is the installer's responsibility to insure that the combined weight load does not exceed the Working Load Limit of any one rigging fitting. This is particularly important if the enclosures are steeply angled upward or downward, as most or all of the weight may be supported by the front or rear points only.



NOTE: A single tall array of up to five (5) ENTASYS columns joined together by the ENTASYS Coupler Bracket(s) may be mounted using a single Pan Bracket Kit. If multiple columns are to be mounted using a Pan Bracket Kit, purchase the ENTASYS Coupler Bracket (part number ENT-CB) and follow the instructions in the complete ENTASYS Installation/Operation Manual included with each ENTASYS column loudspeaker.

For more information on using the ENTASYS Pan Bracket Kit, please refer to the complete ENTASYS Installation/Operation Manual enclosed with each ENTASYS column.

Table 2: Pan Bracket Kit Parts List

Part	Qty
Metal Pan Bracket	2
M6 x 25mm Flat Head Screws	8
6mm Flat Washer	8
6mm Lock Washer	8
M6 Hex Nuts	16

***The installer must supply all other hardware for the installation*

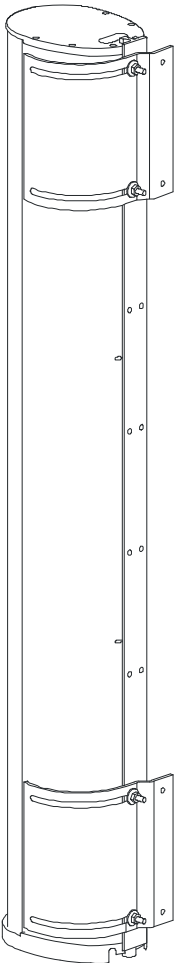
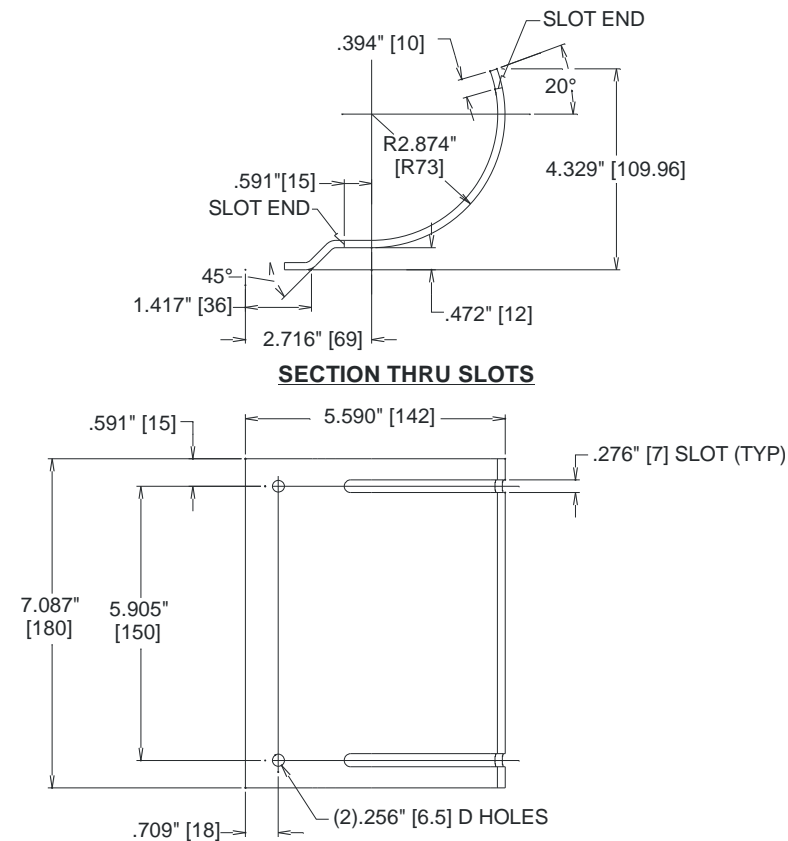

Figure 1: Metal Pan Bracket Dimensions



ENTASYS Pan Bracket Kit Assembly Instructions

1. The ENTASYS T-Bar Mounting Bracket, sometimes referred to as the "T" Mounting Bracket, is included and shipped attached to each ENTASYS column loudspeaker. Remove the T-Bar Mounting Bracket(s) from each ENTASYS column. This is most easily accomplished by either laying the ENTASYS loudspeaker on its side or placing it upside down on a level surface. There are eight set screws, four on each side of the rear of the enclosure, that secure this bracket to the enclosure. Once these are sufficiently loosened, the Mounting Bracket may be slid down parallel to the enclosure, as if pulling it away from the bottom of the enclosure, approximately 3 inches (75 mm). It can then be pulled out of the slot and away from the enclosure.

Figure 2: T-Bar Mounting Bracket Removal

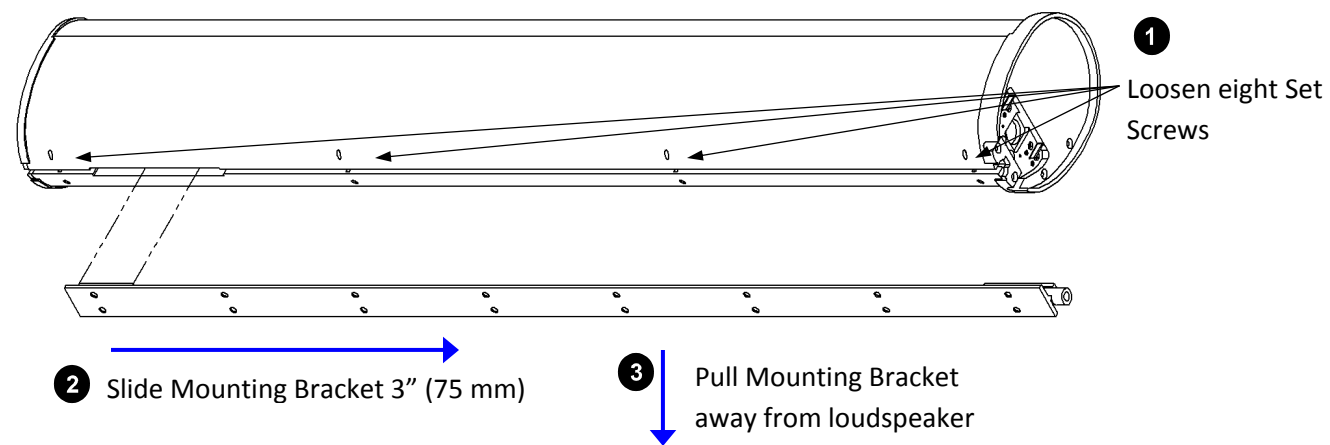

2. Securely fasten eight of the M6 bolts and nuts to the T-Bar Mounting Bracket using four in the uppermost portion of the T-Bar Mounting Bracket and four in the lowermost portion of the T-Bar Mounting Bracket. This will yield eight mounting studs for the Pan Brackets. Do this before attaching either of the Pan Brackets or the washers to the T-Bar Mounting Bracket.

3. Attach one of the Pan Brackets to the uppermost studs on the T-Bar Mounting Bracket and the other Pan Bracket to the lowermost studs on the T-Bar Mounting Bracket using the flat washers, lock washers, and remaining nuts. Tighten the nuts securely.
4. Place the T-Bar Mounting Bracket and Pan Bracket assembly on the wall where the ENTASYS array is to be installed. Mark the positions on the wall where the holes in the Pan Bracket are located.
5. Remove the T-Bar Mounting Bracket and Pan Bracket assembly from the wall and properly prepare the wall to accept the correct type of bolts with which to attach the Pan Bracket assembly to the wall.
6. Attach the T-Bar Mounting Bracket and Pan Bracket assembly to the wall using the proper bolts for the wall material and the weight of the ENTASYS array to be mounted.
7. Loosen the eight M6 nuts between the Pan Bracket and the wall (not the nuts between the T-Bar Mounting Bracket and the Pan Bracket) and rotate the T-Bar Mounting Bracket to its approximate desired aiming location and retighten the nuts.
8. Align the tabs on the T-Bar Mounting Bracket with the larger opening in the slot on the back of the ENTASYS enclosure. Insert the T-Bar Mounting Bracket into the slot in the enclosure and slide the enclosure down onto the T-Bar Mounting Bracket until it is resting on the Bottom Fitting. This is done by simply reversing the order of the steps for removing the bracket as shown in Figure 2.
9. Tighten the eight M4 Set Screws on the ENTASYS enclosure to secure it to the T-Bar Mounting Bracket.
10. When the enclosure is in position, the eight M6 nuts between the Pan Bracket and the wall may be loosened and the array rotated in the Pan Bracket to the final desired aiming position. Once the array is aimed as desired, the eight M6 nuts must be securely tightened to keep the array in position and have a safe mounting.
11. If multiple ENTASYS columns are to be mounted in an array with the Pan Bracket, first connect the individual T-Bar Mounting Brackets using the appropriate number of ENTASYS Coupler Brackets (part number ENT-CB) and perform Step #6 by attaching the entire T-Bar Mounting Bracket and Pan Bracket assembly to the wall. Slide the individual ENTASYS enclosures down onto the T-Bar Mounting Bracket as described in Step #8, starting with the lowermost enclosure. **Make sure the Bottom Fitting is securely fastened to the bottom of the T-Bar Mounting Bracket and Coupler Bracket assembly with its M6 Set Screw. This is critical as the entire weight of the array must be supported by this single Bottom Fitting.** The upper enclosures will not rest on the Bottom Fitting, but instead will rest on the ENTASYS enclosure directly below it. For more information on using the ENTASYS Coupler Bracket with the Pan Bracket Kit, please refer to the complete ENTASYS Installation/Operation Manual enclosed with each ENTASYS column.

Figure 3: Pan Bracket Kit Assembly Diagram (One Column)

